

MAINTENANCE MANUAL

(LINE MAINTENANCE FOR ROTAX[®] ENGINE TYPE 582 UL SERIES)

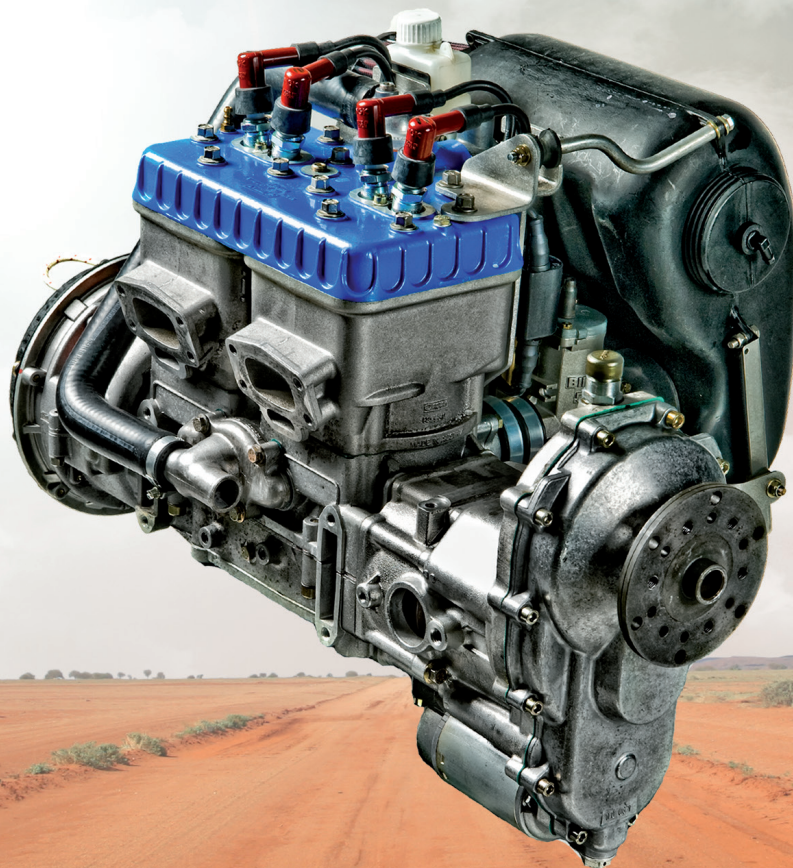

ROTAX[®] 582 UL DCDI Mod. 99 WITH OPTIONS

ROTAX[®] 582 UL DCDI Mod. 17 WITH OPTIONS

WARNING

Before starting any maintenance work, please read the Maintenance Manual completely as it contains important safety relevant information. Failure to do so may result in personal injuries including death. Consult the original equipment manufacturers handbook for additional instructions!

These technical data and the information embodied therein are the property of BRP-Rotax GmbH & CO KG, Austria, acc, BGBl 1984 no. 448, and shall not, without prior written permission of BRP-Rotax GmbH & Co KG, be disclosed in whole or in part to third parties. This legend shall be included on any reproduction of these data, in whole or in part. The Manual must remain with the engine/aircraft in case of sale.

ROTAX® is a trade mark of BRP-Rotax GmbH & Co KG. In the following document the short form of BRP-Rotax GmbH & Co KG = BRP-Rotax is used.

Other product names in this documentation are used purely for ease of identification and may be trademarks of the respective company or owner.

Copyright 2018 © - all rights reserved.

Translation into other languages might be performed in the course of language localization but does not lie within ROTAX® scope of responsibility.

In any case the original text in English language and the metric units are authoritative.

BRP-Rotax
MAINTENANCE MANUAL

Table of Content

Chapter	INTRO – GENERAL NOTE
Chapter	LEP – LIST OF EFFECTIVE PAGES
Chapter	TOA – TABLE OF AMENDMENTS
Chapter	00-00-00 – GENERAL NOTE
Chapter	05-00-00 – MAINTENANCE
Chapter	05-10-00 – TIME LIMITS
Chapter	05-20-00 – SCHEDULED MAINTENANCE CHECKS
Chapter	05-50-00 – UNSCHEDULED MAINTENANCE CHECKS
Chapter	12-00-00 – MAINTENANCE OF THE SYSTEMS
Chapter	12-10-00 – REPLENISHING OPERATING FLUIDS
Chapter	12-20-00 – SCHEDULED MAINTENANCE

BRP-Rotax
MAINTENANCE MANUAL

NOTES

BRP-Rotax
MAINTENANCE MANUAL

Chapter: INTRO
GENERAL NOTE

Foreword

Before carrying out maintenance work on the engine, read this Maintenance Manual carefully.

If any passages of the Manual are not clearly understood or in case of any questions, please contact your nearest ROTAX® authorized Aircraft Engines Distributors or their independent Service Center.

BRP-Rotax wishes you much pleasure and satisfaction flying your aircraft powered by this ROTAX®-aircraft engine.

The structure of the Manual follows whenever it is possible the structure of the ATA (Air Transport Association) standards. The aim is the compatibility with the aircraft manufacturers documentation, which means they must then adapt the documentation to their standard.

BRP-Rotax
MAINTENANCE MANUAL

NOTES

**BRP-Rotax
MAINTENANCE MANUAL**

**Chapter: LEP
LIST OF EFFECTIVE PAGES**

Chapter	Page	Date	Chapter	Page	Date
	Cover page			10	March 01 2018
INTRO	1	March 01 2018		11	March 01 2018
	2	March 01 2018	05-10-00	12	March 01 2018
LEP	1	March 01 2018		1	March 01 2018
	2	March 01 2018		2	March 01 2018
TOA	1	March 01 2018		3	March 01 2018
	2	March 01 2018		4	March 01 2018
00-00-00	1	March 01 2018		5	March 01 2018
	2	March 01 2018	05-20-00	6	March 01 2018
	3	March 01 2018		1	March 01 2018
	4	March 01 2018		2	March 01 2018
	5	March 01 2018		3	March 01 2018
	6	March 01 2018		4	March 01 2018
	7	March 01 2018		5	March 01 2018
	8	March 01 2018		6	March 01 2018
	9	March 01 2018		7	March 01 2018
	10	March 01 2018		8	March 01 2018
	11	March 01 2018		9	March 01 2018
	12	March 01 2018		10	March 01 2018
	13	March 01 2018		11	March 01 2018
	14	March 01 2018		12	March 01 2018
05-00-00	1	March 01 2018	05-50-00	1	March 01 2018
	2	March 01 2018		2	March 01 2018
	3	March 01 2018		3	March 01 2018
	4	March 01 2018		4	March 01 2018
	5	March 01 2018		5	March 01 2018
	6	March 01 2018		6	March 01 2018
	7	March 01 2018		7	March 01 2018
	8	March 01 2018		8	March 01 2018
	9	March 01 2018	12-00-00	1	March 01 2018

BRP-Rotax
MAINTENANCE MANUAL

Chapter	Page	Date
12-10-00	2	March 01 2018
	1	March 01 2018
12-20-00	2	March 01 2018
	1	March 01 2018
	2	March 01 2018
	3	March 01 2018
	4	March 01 2018
	5	March 01 2018
	6	March 01 2018
	7	March 01 2018
	8	March 01 2018
	9	March 01 2018
	10	March 01 2018

Chapter	Page	Date
	11	March 01 2018
	12	March 01 2018
	13	March 01 2018
	14	March 01 2018
	15	March 01 2018
	16	March 01 2018
	17	March 01 2018
	18	March 01 2018
	19	March 01 2018
	20	March 01 2018
	Index	
	Rear page	

BRP-Rotax
MAINTENANCE MANUAL

Chapter: TOA
TABLE OF AMENDMENTS

Approval*
The technical content of this document is approved under the authority of DOA ref.
EASA.21J.048

NOTE

*THE APPROVAL IS GIVEN TO ALL CHAPTERS EXCEPT THE
AIRWORTHINESS LIMITATIONS SECTION 04-00-00 WHICH IS SUBJECT
TO SPECIFIC APPROVAL OF THE EASA.*

Current no.	Chapter	Page	Date of change	Remark for approval	Date of approval from authorities	Date of inclusion	Signature
0	INTRO	all	March 01 2018	DOA*			
0	LEP	all	March 01 2018	DOA*			
0	TOA	all	March 01 2018	DOA*			
0	00-00-00	all	March 01 2018	DOA*			
0	05-00-00	all	March 01 2018	DOA*			
0	05-10-00	all	March 01 2018	DOA*			
0	05-20-00	all	March 01 2018	DOA*			
0	05-50-00	all	March 01 2018	DOA*			
0	12-00-00	all	March 01 2018	DOA*			
0	12-10-00	all	March 01 2018	DOA*			
0	12-20-00	all	March 01 2018	DOA*			

BRP-Rotax
MAINTENANCE MANUAL

Summary of amendments

Summary of the relevant amendments in this context, but without requirement on completeness.

Current no.	Chapter	Page	Date of change	Comment
0	all	all	March 01 2018	new layout and change of company name, add of engine type model year 17

BRP-Rotax
MAINTENANCE MANUAL

Chapter: 00-00-00
GENERAL NOTE

TOPICS IN THIS CHAPTER

General	2
Type description	3
Abbreviations and terms	4
Conversion table	7
Safety notice	8
Safety information	9
Instruction	10
Maintenance Concept.....	11
Technical documentation.....	12
Use for intended purpose	14



BRP-Rotax
MAINTENANCE MANUAL

GENERAL

- Purpose** The purpose of this Manual is to acquaint (iRMT) trained maintenance service staff with some necessary technical requirements for maintaining the engine into the aircraft in compliance with the relevant installation and safety instructions provided by the engine manufacturer.
- Documentation** For more detailed information regarding, installation, maintenance, safety- or flight operation, consult the documentation provided by the aircraft manufacturer and/or dealer.
- For additional information on engines, maintenance or parts, you can also contact your nearest authorized ROTAX®-aircraft engine distributor.
- ROTAX® Distributors** For ROTAX® Authorized Distributors for Aircraft Engines see latest Operators Manual or on the Internet at the official Website www.FLYROTAX.com.
- Engine serial number** When making inquiries or ordering parts, always indicate the engine serial number, as the manufacturer might make modifications to the engine in the course of product improvement. The engine serial number is on the top of the crankcase, magneto side or ignition cover.

BRP-Rotax
MAINTENANCE MANUAL

ABBREVIATIONS AND TERMS

Abbreviations	Description
*	Reference to another section
	center of gravity
	The drop symbol indicates use of sealing agents, adhesives or lubricants (only in the Illustrated Parts Catalog).
°C	Degrees Celsius (Centigrade)
°F	Degrees Fahrenheit
rpm	Revolutions per minute
A	Ampere
AC	alternating current
Ah	Ampere hour
A/C	Aircraft
AR	as required
assy.	assembly
ASB	Alert Service Bulletin
ACG	Austro Control GmbH
API	American Petrol Institute
ASTM	American Society for Testing and Materials
ATA	Air Transport Association
AWG	American Wire Gauge
CW	clockwise
CCW	counter-clockwise
CGSB	Canadian General Standards Board
DCDI	Dual Capacitor Discharge Ignition
DOA	Design Organisation Approval
DOT	Department of Transport
EASA	European Aviation Safety Agency
EN	European Norm
FAA	Federal Aviation Administration
FAR	Federal Aviation Regulations
hr.	hours

BRP-Rotax MAINTENANCE MANUAL

IFR	Instrument Flight Rules
IM	Installation Manual
INTRO	Introduction
IPC	Illustrated Parts Catalog
ips	inch per second
iRMT	independent ROTAX Maintenance Technican
ISA	International Standard Atmosphere
kg	Kilograms
LEP	List of Effective Pages
MMH	Maintenance Manual Heavy
MML	Maintenance Manual Line
MON	Motor Octane Number
MAG	Magneto Side
N	Newton
n.a.	not available
NDT	Non Destructive Testing
Nm	Newton metre
NVFR	Night Visual Flight Rules
OHM	Overhaul Manual
OHV	Over Head Valve
OM	Operators Manual
part no.	Part number
POA	Production Organisation Approval
PTO	Power Take Off
Rev.	Revision
ROTAX®	is a trademark of BRP-Rotax GmbH & Co KG
RON	Research Octane Number
S/N	Serial Number
SAE	Society of Automotive Engineers
SB	Service Bulletin
SI	Service Instruction
SL	Service Letter
SMD	Surface Mounted Devices

BRP-Rotax
MAINTENANCE MANUAL

s.v.	still valid (only Illustrated Parts Catalog)
TBO	Time Between Overhaul
TC	Type certificate
TOA	Table Of Amendment
TOC	Table of content
TSN	Time Since New
TSNP	Time Since New Part
TSO	Time Since Overhaul
V	Volt
VFR	Visual Flight Rules
XXXX	shows the serial component number

BRP-Rotax
MAINTENANCE MANUAL

CONVERSION TABLE

Units of length:	Units of power:
1 mm = 0.03937 in 1 in = 25.4 mm 1 ft = 12 in = 0.3048 m	1 kW = 1.341 hp 1 hp = 0.7457 kW 1 kW = 1.3596 PS 1 PS = 0.7355 kW
Units of area:	Units of temperature:
1 cm ² = 0.155 sq. in (in ²) 1 sq. in (in ²) = 6.4516 cm ²	K = °C – 273,15 °C = (°F – 32) / 1,8 °F = (°C x 1.8) +32
Units of volume:	Units of velocity:
1 cm ³ = 0.06102 cu in (in ³) 1 cu in (in ³) = 16.3871 cm ³ 1 dm ³ = 1 l 1 dm ³ = 0.21997 gal (UK) 1 gal (UK) = 4.5461 dm ³ 1 dm ³ = 0.26417 gal (US) 1 gal (US) = 3.7854 dm ³	1 m/s = 3.6 km/h 1 ft/min = 0.3048 m/min = 0.00508 m/sec 1 m/s = 196.85 ft/min 1 kt = 1.852 km/h 1 km/h = 0.53996 kn
Units of mass:	spec. fuel consumption:
1 kg = 2.2046 lbs. 1 lb. = 0.45359 kg	1 g/kWh = 0.001644 lb/hph 1 lb/hph = 608.277 g/kWh
Density:	Units of torque:
1 g/cm ³ = 0.016018 lb/ft ³ 1 lb/ft ³ = 62.43 g/cm ³	1 Nm = 0.737 ft lb = 8.848 in lb 1 ft lb = 1.356 Nm 1 in lb = 0.113 Nm
Units of force:	Cable cross-section: Conversion table- Wire Gauge: AWG-mm²
1 N = 0.224809 lbf 1 lbf = 4.4482 N	AWG → mm ² 4 → 21 6 → 13 8 → 8.4 10 → 5.3 12 → 3.3 14 → 2.1 16 → 1.3 18 → 0.8 20 → 0.52
Units of pressure:	
1 Pa = 1 N/m ² 1 bar = 100 000 Pa / 1000 hPa / 100 kPa 1 bar = 14.503 lbf/in ² (psi) 1 in Hg = 33.8638 hPa	

BRP-Rotax MAINTENANCE MANUAL

SAFETY NOTICE

Although reading such information does not eliminate any hazards, it promotes understanding and application of the information and will promote correct use of the engine. Always apply common workshop safety rules.

The information and descriptions of components and systems contained in this Manual are correct at the time of publication. BRP-Rotax maintains a policy of continuous improvement of its products without imposing upon itself any obligation to retrofit products previously manufactured.

Revisions

BRP-Rotax reserves the right to remove, replace or discontinue any design, specification, feature or other at any time, and without incurring obligation.

Measurement

Specifications are given in the SI metric system with the imperial- and US customary measurement system equivalents in parenthesis.

Symbols used

This Manual uses the following symbols to emphasize particular information. This information is important and must be observed.

⚠ WARNING

Identifies an instruction which, if not followed, may cause serious injury or even fatal injury.

⚠ CAUTION

Identifies an instruction which, if not followed, may cause minor or moderate injury.

ATTENTION

Identifies an instruction which, if not followed, may severely damage the engine or could void any warranty.

NOTE

Indicates supplementary information which may be needed to fully complete or understand an instruction.

ENVIRONMENTAL NOTE

Environmental notes give you tips on environmental protection.

A revision bar outside the page margin indicates a change to text or graphic.

BRP-Rotax MAINTENANCE MANUAL

SAFETY INFORMATION

Use for intended
purpose

⚠ WARNING

Non-compliance can result in serious injuries or death!

The user has to assume all risks possibly arising from utilizing auxiliary equipment.

⚠ WARNING

Non-compliance can result in serious injuries or death!

Never fly the aircraft equipped with this engine at locations, air speeds, altitudes or in other situations which do not allow a successful no-power landing after sudden engine stoppage.

- This engine is not suitable for aerobatics (inverted flight, etc.). Flight attitudes outside the permissible limits are not allowed.
- It should be clearly understood that the choice, selection and use of this particular engine on any aircraft is at the sole discretion and responsibility of the aircraft manufacturer, assembler or owner/user.
- Due to the varying designs, equipment and types of aircraft, BRP-Rotax grants no warranty on the suitability of its engines use on any particular aircraft. Further, BRP-Rotax grants no warranty on this engines suitability with any other part, component or system which may be selected by the aircraft manufacturer, assembler or user for aircraft application.

⚠ WARNING

Non-compliance can result in serious injuries or death!

For each use of DAY VFR, NIGHT VFR or IFR in an aircraft the applicable legal requirements and other existing regulations must be adhered to.

- In addition to observing the instructions in our Manual, general safety and accident precautions, legal regulations and regulations of any aeronautical authority must be observed.
- Where differences exist between this Manual and regulations provided by any authority, the more stringent regulation shall be applied.
- For continued airworthiness see Maintenance Manual Line.
- Unauthorized modifications of engine or aircraft will automatically exclude any liability of the engine manufacturer for sequential damage.

BRP-Rotax MAINTENANCE MANUAL

INSTRUCTION

Engines require instructions regarding their installation, application, use, operation, maintenance and repair.

Technical documentation and regulations are useful and necessary complementary elements for trainings, but can by no means substitute for theoretical and practical instructions.

These instructions should cover explanation of the technical context, advice for operation, maintenance, installation, use and operational safety of the engine.

Safety notice

In this technical Manual passages concerning safety are especially marked. Pass on safety warnings to other users!

Accessories

This engine must only be operated with accessories supplied, recommended and released by BRP-Rotax. Modifications are only allowed after consent of the engine manufacturer.

Spare parts

See Illustrated Parts Catalog, latest issue.

ATTENTION

Only use genuine ROTAX® spare parts

Spare parts must meet the requirements defined by the engine manufacturer. This can only be guaranteed when using GENUINE-ROTAX®-spare parts and/or accessories (see IPC). Spare parts are available at ROTAX® Authorized Distributors and their independent Service Centers. Any warranty by BRP-Rotax will become void if other spare parts and or accessories than GENUINE-ROTAX®-spare parts and/or accessories are used (see latest Warranty Conditions).

Standard tools / Special tools

ATTENTION

Only use tools and appliances which are suitable for the relevant task according to the latest Manuals.

State of delivery

⚠ WARNING

Engine and gearbox are delivered in “dry“ conditions (without fuel, oil and coolant).

Before putting the engine into operation it must be filled with oil and cooling liquid. Use only oil and coolant as specified.

BRP-Rotax MAINTENANCE MANUAL

MAINTENANCE CONCEPT

General note The maintenance functions detailed in this Manual are divided into two categories:

- Maintenance I (Line Maintenance)
- Maintenance II (Heavy Maintenance)

Repairs beyond the levels detailed in this Manual are not recommended as maintenance functions and must be conducted by an authorized service facility.

Maintenance I (Line Maintenance)

Chapter 00,05 and 12

The scope of line maintenance consists of removal, installation and adjustment of engine components (including part wear). All procedures in this Manual are to be considered line maintenance.

NOTE

Where applicable, you will be referred to the Heavy Maintenance Manual for work above and beyond line maintenance.

Maintenance II (Heavy Maintenance)

Separate Manual.

Maintenance Manual II details removal, installation and repair of components or parts normally considered beyond the scope of the "Line Maintenance".

NOTE

This Manual can only be used in combination with Maintenance Manual I (Line Maintenance), as it builds upon it.

BRP-Rotax MAINTENANCE MANUAL

TECHNICAL DOCUMENTATION

These documents form the instructions ensuring continued airworthiness of ROTAX® aircraft engines.

The information contained herein is based on data and experience that are considered applicable for authorized mechanics (iRMT, see Maintenance Manual Line) under normal conditions for engine removal and installation. Concerning design of engine installations in depth knowledge of aircraft design is required.

Due to the fast technical progress and fulfillment of particular specifications of the customers it may occur that existing laws, safety prescriptions, constructional and operational regulations may not be sufficient or cannot be transferred completely to the object bought, in particular for special constructions.

Documentation

- Installation Manual
- Operators Manual
- Maintenance Manual (Line and Heavy Maintenance)
- Illustrated Parts Catalog
- Alert Service Bulletin
- Service Bulletin
- Service Instruction
- Service Letter



Status

The status of the Manuals can be determined by checking the table of amendments. The first column of this table indicates the revision status, which should be compared with the revision provided on the ROTAX®-Website: www.FLYROTAX.com
Amendments and current versions can be downloaded free of charge.

Replacement pages

Furthermore the Manual is constructed in such a way that single pages can be replaced instead of the complete document. The list of affected pages is given in the chapter LEP. The particular edition and revision number is given on the footer of each page.

Reference

This Manual for maintenance is only part of the technical documentation and will be supplemented by the respective Operators Manual, Installation Manual and Illustrated Parts Catalog.

ATTENTION

Pay attention to references to other documentation, found in various parts of this Manual.

If not stated otherwise, any reference to a document refers to the latest edition issued by BRP-Rotax.

Illustrations

The illustrations in this Manual are merely sketches and show typical arrangements. They may not represent full detail or the exact shape of the parts but should outline the same or

BRP-Rotax MAINTENANCE MANUAL

similar function. Therefore deriving dimensions or other details from illustrations is not permitted.

TYPICAL indicates a general view which may not represent exact details.

NOTE

The Illustrations in this Manual are stored in a graphic data base system and are provided with a consecutive irrelevant number.

This number (e.g. AE 2ST_001) is of no significance for the content.

Some measurements are given in the drawings, these are manufacturing dimensions and are subject to corresponding tolerances.

BRP-Rotax
MAINTENANCE MANUAL

USE FOR INTENDED PURPOSE

⚠ WARNING

Explosion hazard.

Flying components can cause serious injuries.
Never run an engine without propeller.

- Use** The engine ROTAX® 582 UL DCDI mod.99 / mod. 17 is intended for use in uncertified aircraft. In case of doubt the regulations of the national authorities or the respective sportive federations have to be observed.
- Never run the engine without propeller, this inevitably causes engine damage and hazard of explosion.
- Uncertified engines** The engine ROTAX® 582 UL DCDI mod.99 / mod. 17 is uncertified. These engines have not received any safety or durability testing, and conform to no aircraft standards. These engines are meant for use in experimental, uncertified aircraft and vehicles only, in which an engine failure will not compromise safety.
- Engine stoppage** In using the engine the operator assumes all risk of use and acknowledges that he/she knows this engine is subject to sudden stoppage.
- Maintenance and repair conditions** Use for intended purpose also includes observation of the operational, maintenance and repair conditions prescribed by the manufacturer. This is a crucial factor concerning the reliability of the engine and can increase the durability of the engine.

BRP-Rotax
MAINTENANCE MANUAL

Chapter: 05-00-00
MAINTENANCE

TOPICS IN THIS CHAPTER

General note	2
Authorized personnel	3
Procedure notes	4
Trouble shooting	6
Consumable Materials	7
Acceptable methods, techniques and practice	11

Introduction The information given in the Maintenance Manual is based on data and experience which are considered to be applicable for a skilled aviation mechanic (iRMT) under normal working conditions.

BRP-Rotax
MAINTENANCE MANUAL

GENERAL NOTE

⚠ WARNING

Non-compliance can result in serious injuries or death!

Besides our instructions in the documentation supplied, also respect generally valid safety and accident preventive directives and legal regulations.

Procedures and limits	The procedures and limits in this Manual constitute the manufacturers official recommendation for engine maintenance and operation.
Instruction	The guidelines given in the Maintenance Manual are useful and necessary supplements to training. They, however, cannot substitute competent theoretical and practical personal instruction.
Modifications	Non-authorized modifications as well as the use of components and auxiliary components not corresponding to the installation instructions exclude any liability of the engine manufacturer.
Parts and accessories	We particularly emphasize that parts and accessories not supplied as genuine BRP-Rotax parts are not verified for suitability by BRP-Rotax and thus are not authorized for use. Installation and/or use of such products may possibly change or negatively influence the constructive characteristics of the engine. For damages resulting from use of non-genuine parts and accessories manufacturer refuses any liability.
Special tools	Maintenance of engines and systems requires special knowledge and special tools. Use only the special tools recommended by BRP-Rotax when disassembling and assembling the engine.

BRP-Rotax
MAINTENANCE MANUAL

AUTHORIZED PERSONNEL

General note

It is a requirement that all organizations or individuals possess the required special tooling. Technicians must have type-specific training and keep a recurrent knowledge status for the level of work they intend to perform. Technicians may require accreditation from their local aviation authority in addition to any BRP-Rotax requirements.

Requisite knowledge

Any task outlined herein may be performed if the organization or individual has met the following conditions:

Requisite knowledge of the task as a result of:
<ul style="list-style-type: none">• Type-specific training (for the applicable ROTAX® aircraft engine) which is approved by the national aviation authorities and/or BRP-Rotax.
or
<ul style="list-style-type: none">• Experience in performing the task or• Formal instruction from a BRP-Rotax authorized training facility or• Instruction by an authorized BRP-Rotax Distributor representative.
Technicians must:
<ul style="list-style-type: none">• maintain a suitable work environment to prevent contamination or damage to engine parts or modules.• use the required tools and fixtures as outlined in the ROTAX® Maintenance Manual.• ensure reasonable and prudent maintenance practices are utilized.• ensure the requirements of the applicable regulatory authority regarding maintenance procedures are met.

For more detailed information, maintenance organizations and individuals are encouraged to contact BRP-Rotax through its worldwide distribution network for information and guidance on any of the tasks outlined herein.

See [Chapter 00-00-00 section Technical Documentation](#).

Type-specific training

Type-specific training:
<ul style="list-style-type: none">• Independent ROTAX® Maintenance Technician (iRMT) training can be obtained from a ROTAX® approved training organization. Courses are available in various levels to suit the requirements of work the technician needs to perform. Each rating is valid for a 2 year period.

Valid time

ROTAX® iRMT specialty ratings are valid for a 2 year period after initial instruction. Recurrent training is required after 2 years to maintain a current status. In order to be eligible for the renewal program training, the technician must be able to show and declare that they have been working on ROTAX® engines during the past 2 years.

BRP-Rotax
MAINTENANCE MANUAL

PROCEDURE NOTES

General note

⚠ WARNING

Non-compliance can result in serious injuries or death!
When carrying out maintenance and service work, respect without fail all safety regulations.

Ignition “OFF”

⚠ WARNING

Non-compliance can result in serious injuries or death!
This precautionary measure serves to avoid any injuries in case of an unintentional start of the engine.

Principally ensure the following at each maintenance event

- Ignition is “OFF” and system grounded,
- Disconnect battery
and secure engine against unintentional operation.

Ignition “ON”

⚠ WARNING

Risk of electric shock!
The ignition is **switched on**, as long as the ground-cable (P lead) is not properly connected to ground.

At maintenance work which requires ignition “ON” and battery connected, take care of the following:

- Secure the propeller against unintentional turning by hand and
- Secure and observe propeller zone

Handling of operating fluids

⚠ WARNING

Risk of burns and scalds. Hot engine parts.
Always allow engine to cool down to ambient temperature before starting work.

At maintenance of cooling, lubricating and fuel system take care without fail that no contamination, metal chips, foreign material and/or dirt enters the system.

BRP-Rotax MAINTENANCE MANUAL

Disassembly

At disassembly of the engine, mark the components as necessary to avoid any mix-up. Take care of these marks, don't ruin them.

Tool

ATTENTION

In order to avoid mechanical damage, always loosen or tighten screws and nuts with specified tools.

Safety wiring

ATTENTION

If during disassembling/reassembling the removal of a safety item (e.g. safety wiring, self-locking fastener, etc.) should be necessary, it must always be replaced by a new one.

Cleaning of parts

ATTENTION

All metal and synthetic parts should be cleaned with suitable cleaning agents. Before using new and unknown cleaning agents, check their compatibility with the materials they are being used on.

Removed parts

Before re-using disassembled parts, clean, check and refit them as per instructions. Use clean screws and nuts. Always inspect the contact face and thread for damage. If unsure, use new parts.

Self-securing nuts

Once loosened, always replace self-securing nuts.

⚠ WARNING

Non-compliance can result in serious injuries or death!

Exactly observe the tightening torques for screws and nuts. Overtightening or a connection which is too loose could cause serious engine damage.

Sealing rings, O-rings

At reassembly of the engine, replace all sealing rings, gaskets, securing elements, O-rings and oil seals.

Re-assembly

Before re-assembly check components for missing parts. Only use adhesives, lubricants, cleaning agents and solvents indicated in the maintenance instructions. Failure to comply may result in damage.

BRP-Rotax
MAINTENANCE MANUAL

TROUBLE SHOOTING

General notes

Possible problems are listed in the Operators Manual. At the same time, a brief description of the necessary remedial action is given.
See chapter 4 in the Operators Manual for engine type .

BRP-Rotax
MAINTENANCE MANUAL

CONSUMABLE MATERIALS

General note

ATTENTION
Use only the specified or technically equivalent materials from BRP-Rotax for all maintenance work. When handling chemicals, comply with all the customary regulations and specifications of the producer, including the expiry date and instructions of use.

NOTE

To some extent product descriptions deviate in spite of equivalent technical properties, i.e.: LOCTITE 243. If necessary contact the manufacturer concerning the comparability. In some cases information can be obtained from the local authorized distributors and service partners for ROTAX® engines.

NOTE

Respect the manufacturers instruction concerning the curing time and the expiry date of the particular surface sealing compound.

The materials specified have been tested for a long time and are suitable for all operating conditions indicated by the manufacturer.

No.	part no.	Description, Application	Qty.
B	897651	LOCTITE 243,blue medium-duty screw securing agent	10 ml (0.003 gal (US))
C	899788	LOCTITE 648 green, high strength screw securing agent	5 ml (0.001 gal (US))
F	xxx	LOCTITE 7063 For degreasing and cleaning surfaces	AR
H	897870	Filter oil for optimum filter efficiency and protection against moisture	14.8 ml (0.004 gal (US))
I	897330	Lithium-base grease Electrical insulating	250 g (0.55 lb)
M	297433	Molykote G-N, for the prevention of fretting corrosion	100 g (0.22 lb)
P	899791	LOCTITE 5910 black, surface sealing compound, can be used instead LOCTITE 574 and LOCTITE 518	50 ml (0.013 gal (US))

BRP-Rotax
MAINTENANCE MANUAL

No.	part no.	Description, Application	Qty.
V	297386	Locking paint	AR
AG	897186	SILICONE HEAT CONDUCTION COMPOUND, Application of the heat conduction compound will reduce heat transfer resistance. The greaselike, temperature-resistant silicon compound fills cavities between components and the cooling element (e.g.: spark plug-cylinder head), which otherwise do not contribute to heat conduction.	150 g (0.33 lb)

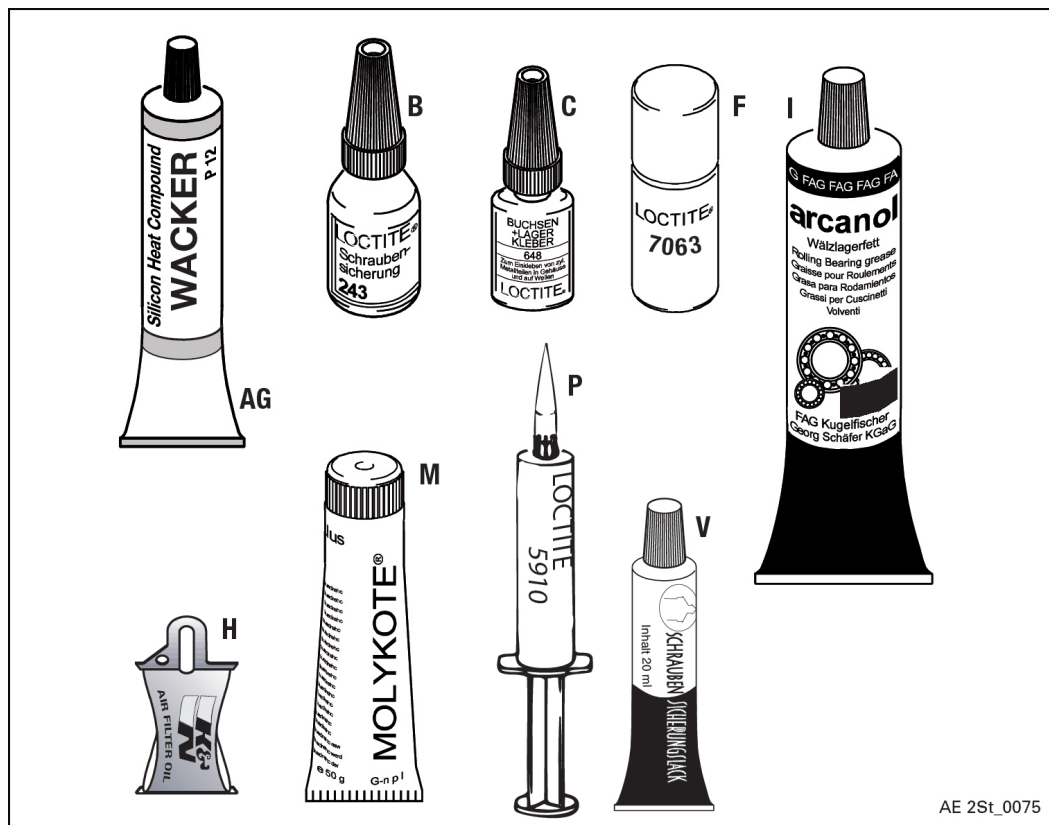

Figure 2.1: Consumable materials

BRP-Rotax
MAINTENANCE MANUAL

**Additional
materials**

ATTENTION			
Use only approved cleaning agents (e.g. kerosine, varsol, etc.) for cleaning all metal parts.			

No.	part no.	Description, Application	Qty.
1	n.a	Cleaning agents Do not use lye-based cold cleaner or degreasing agents. Do not clean coolant or oil hoses with aggressive solutions. Clean off sealing compound residue with sealant remover. Soak combustion chamber, piston and cylinder head with cleaning agent and remove combustion residues with a bronze brush. Very good results have been achieved with "Clenvex 2000". It is a solvent-cold cleaner, free of halogen, on the basis of selected fuel fractions with tenside and is biologically disposable. Never use caustic or corrosive cleaning agents.	AR
2	n.a	Preservation oil This special oil has excellent penetrating capabilities and reaches even tiny gaps, its highly effective additives protect against corrosion of metal surfaces	AR

BRP-Rotax
MAINTENANCE MANUAL

No.	part no.	Description, Application	Qty.
3	n.a	<p>Abrasive pad for surface finishing 3M Scotch-Brite Multi Flex - very fine or ultra fine It sold by the meter and used for manual removal of smaller rust spots or oxidation, especially for optimum ground connections. It is highly suitable for removing LOCTITE from surfaces or threads to make them metallic clean. Before reapplying LOCTITE, clean surfaces with nitro thinners or degreasing agent (CASTROL ZA 30 or OMV-SOFT SOL). When using solvents, observe the safety regulations for persons and environment regarding use and proper disposal.</p>	AR
4	n.a	<p>Compressed air blasting using a solid blasting agent This method is suitable for local and gradual very fine treatment of steel parts with rust film (propeller shaft). The MICRONORM abrasive contains no harmful substances, is approved by the competent authorities and guarantees optimum cleaning. The granulates used are of sizes 40 to 60 μ. The achievable surface roughness is between 0.5 to 1μ, which corresponds to ultrafine machining of surfaces.</p>	AR

BRP-Rotax
MAINTENANCE MANUAL

ACCEPTABLE METHODS, TECHNIQUES AND PRACTICE

General note All general inspection, maintenance and repair has to be carried out in accordance with Advisory Circular AC 43.13 from FAA.

Advisory Circular This Manual "Advisory Circular" AC describes maintenance methods, techniques and practice. These are recognized and authorized for inspection and repairs in non-pressurized areas for which there are no separate maintenance and repair instructions.

Self-locking

ATTENTION

Self-locking nuts, cotter pins, tab washers and safety wires must be replaced each time they have been removed.

All instructions regarding the securing and lubrication of parts must be observed. Adherence to specified torque values is required.

Nut securing When using a self-locking nut, make sure the polyamide insert ring meets the requirements of DIN 985. Be sure that the securing elements on the nut is positioned towards the outside, in accordance with DIN 980.

Lock washer **NOTE**
When fitting lock washers, the curved-up ends (1) must point towards the screw head or nut.

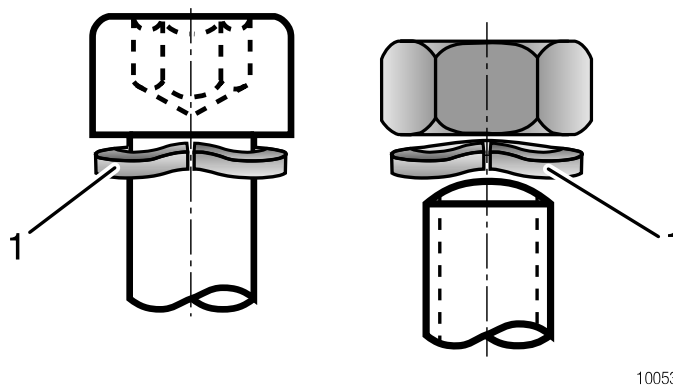

Figure 2.2: Lock washer

Safety wiring Safety wiring serves to secure screws or nuts to prevent unintended loosening. The screw or nuts are secured by a 0.8 mm (.0315 in) safety wire twisted 3 to 4 turns per 10 mm (.4 in.). The wire must by no means be overstretched.

BRP-Rotax MAINTENANCE MANUAL

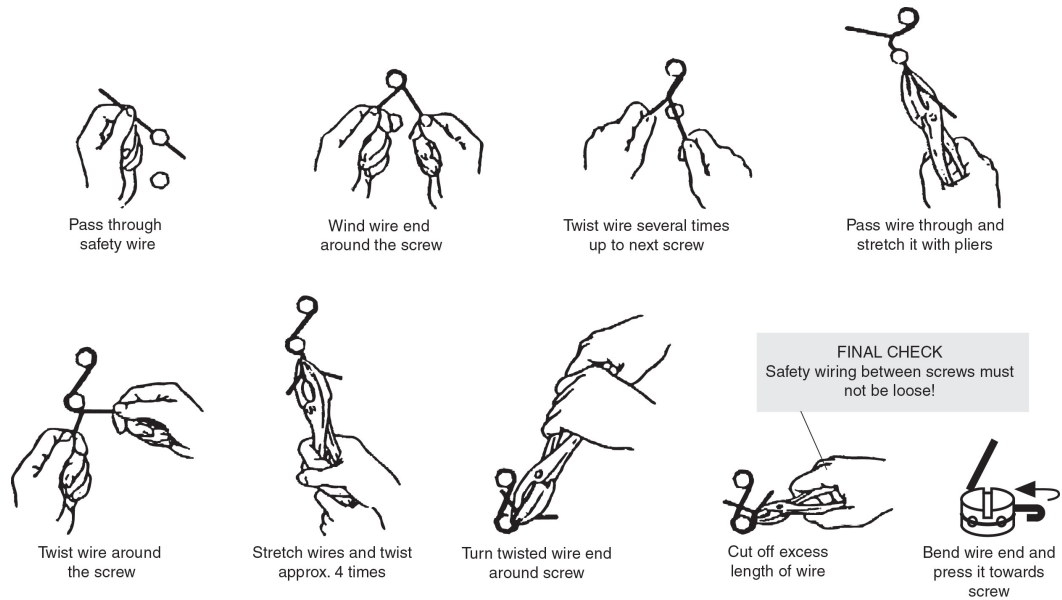

Figure 2.3: Safety wiring

ATTENTION

As a principle, all external engine components and accessories must be wire-secured for safety reasons.

Various typical applications of safety wiring

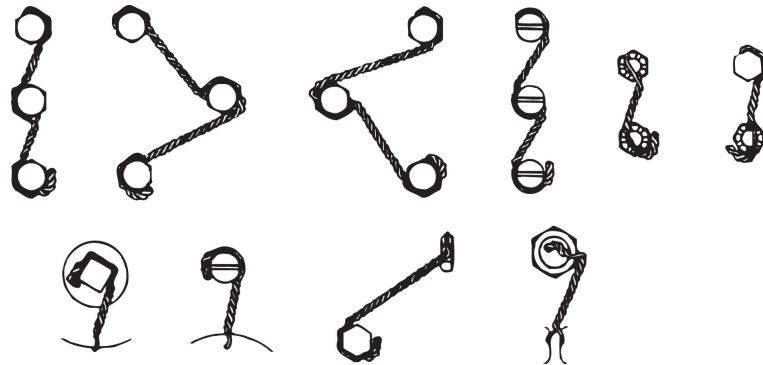

Figure 2.4

Nut securing

When using a self-locking nut, take care that the polyamide insert ring on nuts according to DIN 985 as well as the securing element on nuts according to DIN 980 is positioned towards outside.

BRP-Rotax
MAINTENANCE MANUAL

Chapter: 05-10-00
TIME LIMITS

TOPICS IN THIS CHAPTER

Definition of terms	2
Operating hours	2
Time limit	2
Life cycle	2
General overhaul (TBO).....	2
Time Limit	4
Time limit for parts	5
Time limit for the coolant	5

Introduction The following checks are required at the times specified. This preventative maintenance is to help avoid and/or detect possible engine issues.

BRP-Rotax
MAINTENANCE MANUAL

DEFINITION OF TERMS

OPERATING HOURS

Definition All of the maintenance intervals, such as the 100 hr. inspection and the engine TBO, relate to the number of operating hours of the engine.
The operating hours are defined as follows in order to prevent misunderstandings and to ensure safety:

- All time during which the engine is running is counted towards the total number of operating hours.
- The time is counted irrespective of the load factor of the engine, such as idling or take-off power.

NOTE

A mechanical hour meter is directly coupled to the engine speed, the readings may deviate considerably from those given by electronic remitters (e.g. FlyDat). Maintenance and overhaul intervals are always dictated by the readings of the electronic hour meter.

- The planned inspections to be performed at certain intervals are based on experience from long test runs and field observations. They are intended as precautionary maintenance measures in order to ensure continued trouble-free operation of the engine.

TIME LIMIT

Definition Time limits are predetermined time spans and intervals which are based either on calendar intervals or the number of engine operating hours. Once the time limits have been reached, the affected parts must either be replaced for a general overhaul, or maintenance work must be performed. These precautionary maintenance measures are designed to avoid engine malfunctions or defects and ensure continued airworthiness of the engine.

LIFE CYCLE

Definition The life cycle is always specified as an exact time span and is also quoted in flight hours.

NOTE

Parts with a limited life cycle must be taken out of operation and overhauled if the specified time span or number of flight hours is reached (whichever comes first).

GENERAL OVERHAUL (TBO)

Definition The time between overhauls (TBO) for all objects (such as the engine, component assemblies, add-on components) is the approved length of operation under normal operating conditions before it becomes mandatory to send in these objects for an overhaul. Normal operating conditions are the conditions which comply with the manufacturer's and the aviation authority's recommendations for the certification of airworthiness.

BRP-Rotax MAINTENANCE MANUAL

Maintenance of operation	The TBO values approved by the relevant authorities are based on performance tests and empirical values which have been gathered through operation of the engine and are required for the acceptance and certification of airworthiness.
Legal obligation to keep	TBO values for the engine are always shown in operating hours and years. The user must record the operating hours in the engine log book.

BRP-Rotax
MAINTENANCE MANUAL

TIME LIMIT

General

ATTENTION
A general overhaul is due after a defined period of operation or after a specified calendar life since initial start of operation (whichever comes first).

The time limit for engine operation will be specified by the TBO.

After reaching this time limit

ATTENTION
After reaching this time limit, the engine has to be shipped to an authorized ROTAX® overhaul facility.

For an overhaul, the engine must be removed from the aircraft, be cleaned, preserved and all openings to be closed to prevent entering of contaminants.

Storage period of the engine

Observe the storage and preservation directives!

NOTE

The maximum possible storage period of the engine is limited to 24 months.

If this period is exceeded, the engine must be sent to an ROTAX® authorized overhaul facility for inspection.

Engine Type description	Engine affected engine S/N	TBO Time Between Overhaul
582 UL Mod. 99	from S/N 5305902 up to S/N 9619115 inclusive	300 h or 5 years, whichever comes first ¹
582 UL Mod. 17	from S/N 9619116	300 h or 5 years, whichever comes first ¹

For the TBO of the specific engine type/version refer to the table below.

Authorized exceeding

Extension or exceeding of the TBO by 5% or 6 months is allowed whichever comes first.

Shipment

The shipment to an authorized ROTAX® overhaul facility must include the following:

1	Engine log book.
2	Maintenance records of the engine (i.e. all maintenance check lists, and reports of operation, of maintenance, of findings and of oil analysis).

BRP-Rotax MAINTENANCE MANUAL

3	The engine assembly as per supply volume. Additionally all added-on parts as in the supply volume such as filters, intake silencer, fuel pump, external generator, sensors, ignition unit, electric starter, oil tank.
4	Indication of total engine operating hours (TSN) and where applicable, engine operating hours since a previous overhaul (TSO). NOTE <i>This information must be supplied to allow the service history of components to be traced.</i>
5	Data about the type of aircraft used.
6	Useful remarks and observations concerning the engine.

TIME LIMIT FOR PARTS

General note

ATTENTION

This time limit must be followed independently and in addition to the visual inspections (see Chapter 05-20-00 section: Visual Inspection) of the respective components.

Time limit

The following components and systems must be replaced every 5 years:

- Venting hose of the carburetors
- Carburetor sockets
- All rubber hoses of the cooling system
- All rubber hoses of the fuel system
- All rubber hoses of the lubrication system which are part of the engine supply volume and if they are not in the maintenance schedule of aircraft manufacturer

TIME LIMIT FOR THE COOLANT

General note

Coolant must be replaced as per manufacturers instructions, at the latest during overhaul or when the engine is replaced.

BRP-Rotax
MAINTENANCE MANUAL

NOTES

Notes

Page 6
March 01 2018

Effectivity: 582 UL
Edition 1/Rev. 0

BRP-Rotax
MAINTENANCE MANUAL

Chapter: 05-20-00
SCHEDULED MAINTENANCE CHECKS

TOPICS IN THIS CHAPTER

Scheduled maintenance checks	2
Unscheduled maintenance checks	3
Visual inspection	4
Maintenance schedule procedures (maintenance check list)	5
Check List/Maintenance Schedule.....	6
Maintenance Schedule	8

Introduction The owner and/or user is primarily responsible for the maintenance and airworthiness of the engine. This includes compliance with all applicable airworthiness directives.

This inspection protocol is not intended to be all-inclusive, for no such protocol can replace the knowledge and experience of a certified aircraft mechanic. As the party primarily responsible for the maintenance and airworthiness of the engine, the owner or user should only have the maintenance work carried out by qualified engineers (corresponding to the iRMT levels).

Documentation required It is the responsibility of the owner and/or user to make sure that the aircraft mechanic performing the work on the engine has access to the previous Inspection Protocols and any other required documents.

BRP-Rotax MAINTENANCE MANUAL

SCHEDULED MAINTENANCE CHECKS

Definition This section lists the periodic inspections which must be carried out after a specified periods of operation.

Intervals Periodic inspections are those which must be performed at 12.5, 100, 150 hr. intervals in accordance with [Chapter 05-20-00 section Maintenance Schedule](#). This means for example that. **every 100 hr** of operation a 100 hr. check must be carried out. Every 200 hr. of operation a 100 hr. and the additional checks for 200 hr. must be carried out.

	Intervals –hours								to	every 300 hr
	2 hr	10 hr	25 hr	every 12.5 hr	every 25 hr	every 50 hr	every 100 hr	every 150 hr		
12.5 hr				X						
100 hr				X	X	X	X			
150 hr				X	X	X		X		

- For the intervals between maintenance work, a tolerance of ± 10 hr. is permissible, but these tolerances must not be exceeded. This means that if a 100 hr. check is actually carried out at 110 hr., the next check will be due at 200 hr. ± 10 hr. and not at 210 hr. ± 10 hr.
- If maintenance is performed before the prescribed interval, the next maintenance check is to be done at the same interval (e.g. if first 100 hr. check is done after 87 hours of operation, the next 100 hr. check must be carried out after 187 hours of operation).
- If engine has less than 100 hours of operation during one year a 100 hr. check must be carried out. For the annual inspection a tolerance of ± 2 months is given.

Checks

- In order to demonstrate continued airworthiness, an engine must be inspected after the first mentioned hours of operation.

BRP-Rotax
MAINTENANCE MANUAL

UNSCHEDULED MAINTENANCE CHECKS

Operating limits exceeded

An inspection of the engine must be performed if the operating limits of the engine have been exceeded (e.g. overspeed, excessive temperature etc.), or if unusual operating conditions have occurred during operation (e.g. lightning strike). In such cases the engine must be inspected in accordance with the applicable unscheduled maintenance checks.

Recommends inspections

The manufacturer also recommends the following inspections whenever maintenance is carried out (where not already prescribed by the airframe manufacturer) as possible malfunctions could have negative effects on engine operation.

part	inspection	possible danger
Exhaust fixation	<ul style="list-style-type: none"> • Re-tighten the exhaust fixation on the cylinder head after the first 2 hr. of operation 	Leakage
Exhaust	<ul style="list-style-type: none"> • Of the exhaust unit (where necessary, replaced application of Molykote G-N) 	Risk of fracture, wear. Rough engine running.
Fuel filter	<ul style="list-style-type: none"> • Of fuel filter on airframe side (for foreign bodies, sealing material and loose fragmented material) 	Engine may misfire. Power loss. Engine running too lean (Engine malfunction and damage).
Oil	<ul style="list-style-type: none"> • For oil contamination • Analysis of the oil (provides additional information on the condition of the engine) 	Possible engine wear
Radiators, Lines	<ul style="list-style-type: none"> • For damage • Check for discoloration - and cracks. 	Danger of overheating
Throttle control	<ul style="list-style-type: none"> • As specified by the cell manufacturer 	See specifics of manufacturer.

BRP-Rotax
MAINTENANCE MANUAL

VISUAL INSPECTION

General note	The scope of a visual inspection generally includes, but is not necessarily limited to, the following.
Moving parts	Normal operating condition, accurate alignment, leak-tightness, cleanliness, ease of movement, adjustment, mechanical stress, travel, catching, extreme wear, cracks, corrosion, deformation and other visually evident damage.
Parts	Secure seating, surface condition, cleanliness, deformation, cracks in welding seams or due to material fatigue or stress, corrosion and other visually evident damage.
Fuel-, Air- and Oil lines and Hoses	Cracks, dents, kinks, required flexibility, collapsed lines/hoses, abrasion, cleanliness, secure seating and other visually evident damage.
Wiring	General cleanliness; loose, corroded or broken terminals; chafed, broken or worn insulation; secure seating, heat damage and other visually evident damage.
Screws and Nuts	Surface damage, secure seating, locking wire, securing paint and other visually evident damage.
Filter and Screens	Filters and screens must be inspected for contamination and potential blockages, cleaned and replaced as required.

BRP-Rotax
MAINTENANCE MANUAL

MAINTENANCE SCHEDULE PROCEDURES
(MAINTENANCE CHECK LIST)

Inspections	All stated checks are visual inspections for damage and wear, unless otherwise stated.
Specified period	All listed work must be carried out within the specified period.
Maintenance check lists	Checks are carried out as per the maintenance check lists, where type and volume of maintenance work is outlined in key words. <ul style="list-style-type: none">• The lists must be photocopied and filled out for each maintenance check.
Extra inspections	<ul style="list-style-type: none">• The respective check (e.g. 100 hr. check) must be noted on the top of each page of the maintenance check list.• All the maintenance work carried out must be initialled in the "signature" area by the aircraft mechanic performing the task.
Maintenance records	After maintenance, the completed check lists must be entered in the maintenance records. The maintenance must be confirmed in the log book.
Discrepancies/remedial action	All discrepancies and remedial action must be recorded in a report of findings to be generated and maintained by the company authorized to carry out maintenance work. It is the responsibility of the aircraft operator to store and keep the records.
Replacement of equipment	Replacement of equipment (e.g. fuel pump, ...) and execution of SB (LTA) must be entered in the engine log book, TSN and date.

BRP-Rotax
MAINTENANCE MANUAL

CHECK LIST/MAINTENANCE SCHEDULE

Identification	
AIRCRAFT	
Registration number	
Aircraft make	
Aircraft model and S/N	
Time since new	
Propeller	
Propeller brand	
Propeller model and S/N	
ENGINE	
Engine type	
Engine S/N	
TSN (time since new)	
TSO (time since overhaul)	
Used operating fluids:	
Coolant	
• mixture ratio	
Fuel	
Oil	
• type	
• viscosity	

BRP-Rotax
MAINTENANCE MANUAL

Identification	
AIRCRAFT OPERATOR	
Name	
Contact	
Address	
Telephone/Fax	
E-mail	
MAINTENANCE FACILITY	
Maintenance workshop	
Address	
Telephone/Fax	
E-mail	
Certificate	
)1leaded fuel more than 30% of operation	
Next check due at:	hr.
	(TSN_____) (engine hr.)

BRP-Rotax MAINTENANCE MANUAL

MAINTENANCE SCHEDULE

Perform the following maintenance tasks at the intervals shown in the maintenance check list.
See Chapter 05-20-00 section 25 hr. check.

Legend: X = do the task
 blank = no task required

NOTE

If the table section 1) 2) and 3) are correct (see check list below) then continue with the maintenance schedule.

If one of the section 1) 2) or 3) is not within specification, the engine must be checked and repaired in accordance with the BRP-Rotax instructions for continued airworthiness.

Points of Inspection	Interval Operating hours										Chapter Reference	Signature
	2	10*	25*	every 12.5	every 25	every 50	every 100	every 150	every 300			
*no periodic maintenance (requirement exclusive after the mentioned hours of operation)												
1) General note												
All (Alert) Service Bulletins are complied with. If necessary to perform these and documented.	X				X							
2) Spark plug												
Check and clean inside of spark plug connectors.				X		X ⁽²⁾					12-20-00	
Remove all spark plugs and check for spark plug defects (deposits, melting....).				X		X ⁽²⁾					12-20-00	
>>												

BRP-Rotax
MAINTENANCE MANUAL

Points of Inspection	Interval Operating hours										Chapter Reference	Signature
	2	10*	25*	every 12.5	every 25	every 50	every 100	every 150	every 300			
*no periodic maintenance (requirement exclusive after the mentioned hours of operation)												
Check if GENU-INE-ROTAX®-spark plugs are used on mod. 17.					X						12-20-00	
Replace spark plugs					X	X ⁽²⁾					12-20-00	
(2 only for mod. 17)												
3) Checking gearbox oil level												
Checking gearbox oil level					X						12-20-00	
4) Oil change												
Replace gearbox oil		X					X				12-20-00	
Replace rotary valve lubrication oil							X				12-20-00	
5) Check and adjust gearbox												
Check and adjust gearbox, preload of springs (type B gearbox)							X				12-20-00	
6) Check carburetors												
Check, if necessary clean carburetor(s) and re-adjust (idle speed, cable tension,..)	X					X					12-20-00	
Replace jet needle and needle jet								X			12-20-00	

BRP-Rotax
MAINTENANCE MANUAL

Points of Inspection	Interval Operating hours									Chapter Reference	Signature
	2	10*	25*	every 12.5	every 25	every 50	every 100	every 150	every 300		
*no periodic maintenance (requirement exclusive after the mentioned hours of operation)											
7) Check fuel pump											
Check fuel pump (measure fuel pressure)						X					12-20-00
8) Exhaust system											
Retorque exhaust manifold screws	X	X									12-20-00
Lubricate ball joints					X						12-20-00
Replace exhaust muffler springs							X				12-20-00
9) Clean and oil air filter											
Clean and oil air filter.					X						12-20-00
10) Fuel filter											
Check fuel filter					X						12-20-00
Replace fuel filter							X				12-20-00
11) Check rewind starter rope											
Check rewind starter rope				X							12-20-00
12) Check electric starter gear											
Check electric starter gear						X					see MMH
13) Check ignition system											
Check ignition system					X						12-20-00

BRP-Rotax
MAINTENANCE MANUAL

Points of Inspection	Interval Operating hours									Chapter Reference	Signature
	2	10*	25*	every 12.5	every 25	every 50	every 100	every 150	every 300		
*no periodic maintenance (requirement exclusive after the mentioned hours of operation)											
14) Check cylinder head and piston crown											
Inspect cylinder head and piston crown						X					see MMH
15) Piston inspection											
Inspect piston rings for free movement						X					see MMH
Check piston diameter						X ⁽¹⁾		X			see MMH
Piston ring: Check gap						X ⁽¹⁾		X			see MMH
Piston ring (rectang. Ring): Check axial clearance						X ⁽¹⁾		X			see MMH
(1 if used in very dusty atmosphere)											
16) Piston pin inspection											
Inspect piston pin and bearing								X			see MMH
17) Cylinder inspection											
Check cylinder diameter						X ⁽¹⁾		X			see MMH
Cylinder: Check for roundness						X ⁽¹⁾		X			see MMH
(1 if used in very dusty atmosphere)											

BRP-Rotax
MAINTENANCE MANUAL

Points of Inspection	Interval Operating hours									Chapter Reference	Signature
	2	10*	25*	every 12.5	every 25	every 50	every 100	every 150	every 300		
*no periodic maintenance (requirement exclusive after the mentioned hours of operation)											
18) Gasket exchange											
Replace cylinder head-, cylinder base- and exhaust-gasket						X ⁽¹⁾			X	see MMH	
(1 if used in very dusty atmosphere)											
19) Outer seals crankshaft											
Inspect crankshaft and replace outer seals if necessary.									X	see MMH	
20) Overhaul of engine											
General overhaul of engine									X ⁽²⁾	see MMH	
(2 to be carried out every 5 years or every 300 hours whatever comes first.											

BRP-Rotax
MAINTENANCE MANUAL

Chapter: 05-50-00
UNSCHEDULED MAINTENANCE CHECKS

TOPICS IN THIS CHAPTER

Engine check after propeller strike incidents	2
Examination after engine failure	3
Returning engine to service after submerging in water	4
Inspection in extreme climatic conditions	5
Returning engine to service after influence by fire	5
Required inspections after limits of operation have been exceeded	6
Reporting	6

Introduction

Special checks must be carried out immediately in the event of an engine fault (e.g. abnormal operation as defined in the Operators Manual) which impairs the airworthiness of the engine.

ATTENTION
In the course of special checks specify if additional checks for components (e.g. hydraulic governor) is applicable. After each special check/repair work, an engine test run and a leakage check must be carried out.

ATTENTION
Observe without fail all the specified instructions.

BRP-Rotax
MAINTENANCE MANUAL

ENGINE CHECK AFTER PROPELLER STRIKE INCIDENTS

Definition

A propeller strike is:

- Any incident while the engine is stationary or running which makes it necessary to perform repairs on the propeller.

SL-2ST-009, current edition.

BRP-Rotax
MAINTENANCE MANUAL

EXAMINATION AFTER ENGINE FAILURE

General note

In order to find possible causes of the failure, it is important to pass on all available data. Observations on the aircraft and the engine suspension can also be of help. It is important to pay particular attention to any of the following engine phenomena to facilitate troubleshooting.

Engine

Engine runs erratically and misfires	
part	possible cause
Fuel system	fuel supply vapour locks contamination
Ignition system (shorting cable, charging coil, Spark plug)	malfunction grounding defect wrong spark plug connection loose connection

Rough running engine

Rough running engine	
part	possible cause
Ignition	wiring (assignment fault)
Engine	engine temperature too low wrong intake air
Carburetor	fuel supply inadequate contamination in float chamber or float needle valve float chamber venting false air intake due to defective carburetor flange incorrect synchronization of the carburetor

BRP-Rotax MAINTENANCE MANUAL

Engine stoppage

ATTENTION

Should one of the above mentioned items occur even for a short time then a detailed check of the engine is necessary. The fault needs to be located and corrected.

Unintended engine stoppage by seizing	
part	possible cause
Oil system Carburetors Gaskets/Seals	oil shortage contamination incorrect venting incorrect oil type incorrect carburetor setting leaking seals
Oil pump	defect

ATTENTION

The entire assembly must be dismantled, inspected and repaired.

- The whole engine must be inspected, repaired or overhauled in accordance with the BRP-Rotax instructions for continued airworthiness.
- Inspect all systems for correct functioning.
- Detailed inspection of affected engine components.

RETURNING ENGINE TO SERVICE AFTER SUBMERGING IN WATER

General note

ATTENTION

The engine must be marked clearly “Engine submerged in water“. Define if it was fresh water or salt water.

An engine which has been submerged in water must be inspected, repaired or overhauled in accordance with the BRP-Rotax instructions for continued airworthiness. See current Maintenance Manual of the respective engine type.

Inspection

- Inspect all systems for correct functioning.

NOTE

Prior to the detailed inspection, all parts should be cleaned and inspected for corrosion. For accessories (e.g. vacuum pump, fuel filter etc.) the instructions and specifications of the corresponding manufacturer must be followed.

BRP-Rotax MAINTENANCE MANUAL

Complete inspection of these components:	
• power supply	• cooling system
• gearbox	• exhaust system
• fuel system	• start system
• cylinder unit	

In most cases an overhaul is necessary, in this regard send the engine without delay to an authorized ROTAX® overhaul facility for inspection.

If an engine was submerged into water, all electrical components (e. g.: ignition coils, spark plugs, spark plug connectors must be replaced.

NOTE

Discoloration or corrosion are signs of submerging in water.

INSPECTION IN EXTREME CLIMATIC CONDITIONS

General note

ATTENTION
Every 25 hr. checks of air filter, coolant radiator and oil cooler are necessary.

Flying in deserts or areas with heavily contaminated or dusty air causes increased wear on all components. For this reason, shorter maintenance intervals are recommended.

Flying in areas with extreme climatic conditions or in extreme altitudes requires adjustment of the cooling system. To do this, it is necessary to contact the aircraft manufacturer and an authorized ROTAX® aircraft engines distributor.

RETURNING ENGINE TO SERVICE AFTER INFLUENCE BY FIRE

General note An engine after influence by fire must be inspected, repaired or overhauled in accordance with the BRP-Rotax instructions for continued airworthiness.

Inspection • Inspect all systems for correct functioning.

NOTE

Prior to the detailed inspection, all parts should be cleaned and inspected for weld penetration or melted materials.

If an engine was influenced by fire, first a visual inspection of all parts has to be done and then a hardness test of all mechanical parts must be performed (e. g.: crankcase, cylinder, cylinder heads etc.).

BRP-Rotax MAINTENANCE MANUAL

In most cases an overhaul is necessary, in this regard send the engine without delay to an authorized ROTAX® overhaul facility for inspection.

REQUIRED INSPECTIONS AFTER LIMITS OF OPERATION HAVE BEEN EXCEEDED

Exceeding of max. permissible engine speed

Remove the cylinders and inspect the pistons for seizure.

Exceeding of max. permissible cylinder head temperature

Remove the cylinders and inspect the pistons for seizure and piston crown for crushes.

Exceeding of max. permissible exhaust gas temperature

Remove the cylinders and inspect the pistons for seizure.

Fuel pressure below specified value

Remove the cylinders and inspect the pistons for seizure. Also inspect crankshaft end seals for leakage.

REPORTING

General note

According to the regulation of EASA part 21A.3 / FAR 21.3 the manufacturer shall evaluate field information and report to the authority. In case of any relevant occurrences that may involve malfunction of the engine, the form on the next page should be filled out and sent to the responsible ROTAX® Authorized Aircraft engines distributor or their independent Service Center.

NOTE

The form is also available from the official ROTAX® AIRCRAFT ENGINES Website in electronic version.

www.FLYROTAX.com

BRP-Rotax MAINTENANCE MANUAL

Customer Service Information Report		ROTAX [®] AIRCRAFT ENGINES	
When / Where / What			
Accident / Incident Date:		State:	
Location Of Occurrence:			
Headline:			
Narrative:			
Aircraft identification			
Aircraft registration:		Aircraft category:	
Manufacturer:		Model / Series:	
Serial number:		Aircraft total time:	
Flight details			
Flight phase:		Operator:	
Last departure point:		Planned destination:	
Engine information			
Type:		Serial number:	
Time since new [h]:		Time since overhaul [h]:	
Date overhaul:		Date inspection / maintenance:	
Propeller information			
Manufacturer:		Model / Series:	
Serial number:		Propeller position:	

BRP-Rotax GmbH & Co KG / EASA.21J.048

www.flyrotax.com

Figure 5.1: Form

BRP-Rotax
MAINTENANCE MANUAL

NOTES

BRP-Rotax
MAINTENANCE MANUAL

Chapter: 12-00-00
MAINTENANCE OF THE SYSTEMS

TOPICS IN THIS CHAPTER

Introduction

The section "Maintenance of the systems" is associated with other sections. It serves only as a supplement to and further explanation of the maintenance check list (See 05-20-00).

NOTE

For reasons of clarity, only headlines and keywords are listed in the Maintenance Schedule. Please refer to the following pages for further explanation if needed. As far as possible, the content has been arranged according to system.

BRP-Rotax
MAINTENANCE MANUAL

NOTES

Notes

Page 2
March 01 2018

Effectivity: 582 UL
Edition 1/Rev. 0

BRP-Rotax
MAINTENANCE MANUAL

Chapter: 12-10-00
REPLENISHING OPERATING FLUIDS

TOPICS IN THIS CHAPTER

Fluid capacities2

Introduction The engine should always be in a horizontal position before checking the fill levels.

ENVIRONMENTAL NOTE

All operating materials and cleaning products endanger the environment by improper disposal.

Dispose of the operating materials in an environmentally sound way!

BRP-Rotax
MAINTENANCE MANUAL

FLUID CAPACITIES

General note

ATTENTION
The operation of the engine may be adversely affected if non-approved or contaminated fuel, oil or coolant are used. Any mixing of different manufacturers and types should be avoided. The use of additives may result in damage.

System

Overview

System	Fill capacity	Details about the operating fluids
Fuel system	Refer to the relevant specifications provided by the aircraft manufacturer.	Refer to the corresponding chapter in the Flight Manual.
Cooling system	Approx. 1.5 l (0.4 US gal.).	Refer to the corresponding chapter in the Operators Manual.

NOTE

BRP-Rotax can give an approx value on the fill capacity depending on aircraft design and positions of radiators and tanks. The volume may differ from this value. Always check the relevant specifications provided by the aircraft manufacturer.

BRP-Rotax
MAINTENANCE MANUAL

Chapter: 12-20-00
SCHEDULED MAINTENANCE

TOPICS IN THIS CHAPTER

Spark plugs	2
Check and clean inside of spark plug connectors	2
Inspection of spark plugs.....	2
Replacement of spark plugs	6
Propeller gearbox	8
Checking the propeller gearbox	8
Oil change	9
Carburetor	11
Clean carburetor and check for wear.....	11
Replace jet needle and needle jet	11
Fuel pump	12
Exhaust system	13
Retorque of exhaust manifold screws.....	13
Lubricate ball joints.....	13
Replace exhaust muffler springs	13
Air filter	15
Cleaning the air filter.....	15
Application of new air filters	16
Fuel filter	17
Check and replacement of fuel filter	17
Rewind starter	18
Check of ignition system	20

Introduction This chapter relates in particular to the maintenance work mentioned in the Maintenance Schedule for the various engine systems and covers the work in more detail.

BRP-Rotax
MAINTENANCE MANUAL

SPARK PLUGS

CHECK AND CLEAN INSIDE OF SPARK PLUG CONNECTORS

Instruction	Step	Procedure
	1	Inspect spark plug connector for cracks, burn-off, dampness and fouling. Check connection with ignition cable and fitting of rain protection cover.
	2	The resistance value of the standard plug connector is 4.5 – 5.5 kΩ.

Mod. 99 only

For various applications radio interference suppression plug connectors must be used according to respective regulations. These are more prone to troubles than the standard resistor type connector, due to the metal shielding. Resistance of these connectors is 0.8 – 1.2 kΩ.

Never pull off spark plug connector on a running engine.
Clean contact surfaces in the spark plug connectors as required.

Mod. 99 only

ATTENTION

On engine installation with spark plugs down, it is highly recommended to additionally secure spark plug caps.

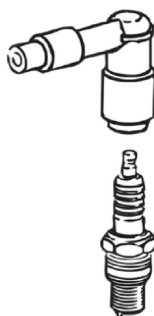

"OLD" 866705



"NEW" 265249

AE 2ST_0076

Figure 7.1: Spark plug connector for mod. 99 (left) and mod. 17 (right)

INSPECTION OF SPARK PLUGS

Spark plugs for mod. 99:

Visual check

Inspect all spark plugs for mechanical damage.

Due to varying fuel properties etc., check according to maintenance schedule. Replace as required or annually: Provided that spark plug heat range and the carburetor calibration are correct, the spark plugs will have a brownish tinge at the electrodes of both spark

BRP-Rotax MAINTENANCE MANUAL

plugs after full load operation. In numerous tests the best possible heat range has been determined to make sure that the spark plug will burn off deposits but will not overheat.

On engines with single carburetor, one sooty spark plug usually indicates a bad plug or fault ignition system. If both plugs are sooty with oil deposits, carburetor and air system should be checked. On engines with two carburetors you should switch the carburetor to trace the problem.

Spark plugs for mod. 17:

Due to the curved gap between the center electrode and the ground electrodes, it is suggested to use a wire type feeler gauge for accurate gap measurement.

All versions:

ATTENTION

Do not induce forces to the center electrode of the spark plug. These might damage the spark plug.

Electrode gap

NOTE

Spark plugs are already gapped upon delivery. No adjustment of the gap is necessary nor allowed.

If gap measurement is over permissible limit, the spark plug must be replaced.

Electrode gap	
Mod. 99	0.4 - 0.5 mm (0.016 - 0.020 in.), wear limit: 0.5 mm (0.020 in.)
Mod. 17	0.8 - 0.9 mm (0.031 - 0.035 in.), wear limit: 1.1 mm (0.043 in.)

BRP-Rotax MAINTENANCE MANUAL

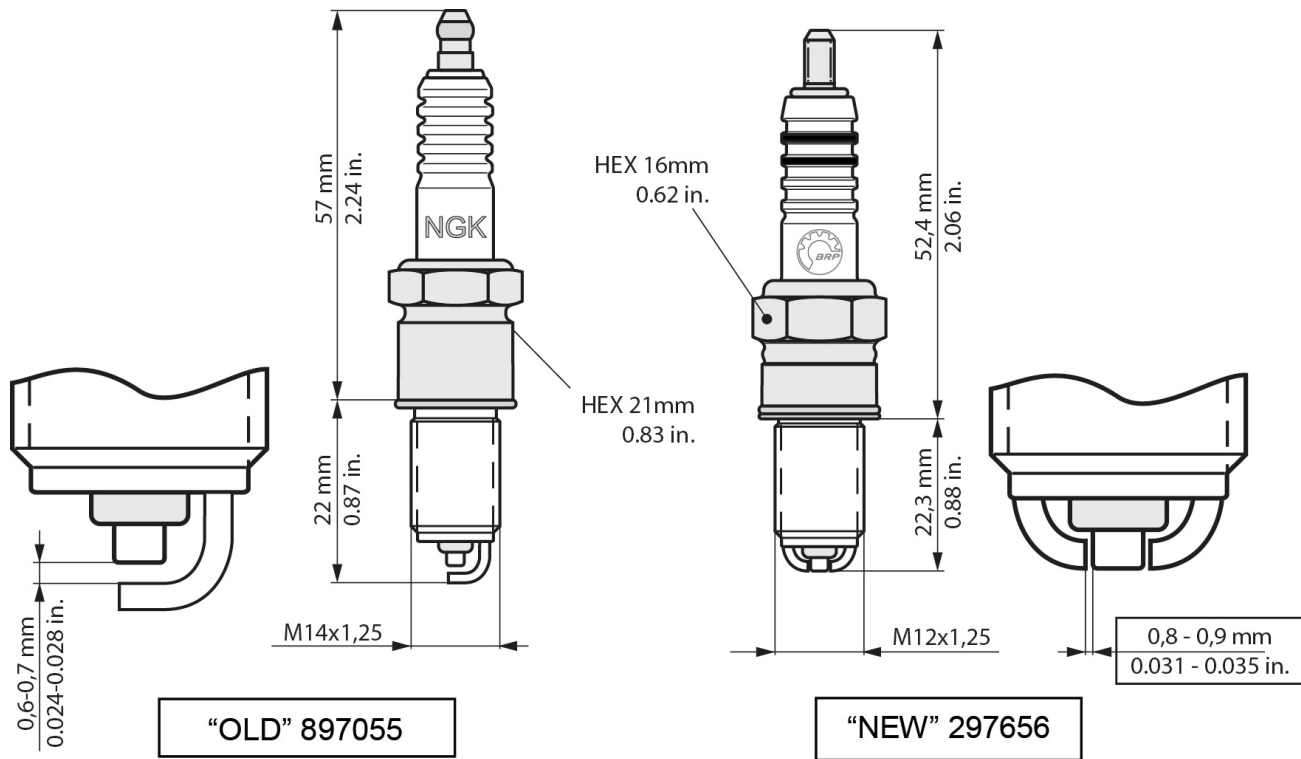

AE 2ST_0077

Figure 7.2: Spark plug dimensions

Spark plug face Spark plug face reveals the following about the operating condition of the engine:

Spark plug face	Information
light colored to brown	plug and calibration of the engine are correct
velvet black	Possibly indicates one or more of the following: <ul style="list-style-type: none"> • mixture too rich • insufficient air intake (clogged air filter) • engine operating temperature too low
oily, glossy coating	Possibly indicates one or more of the following: <ul style="list-style-type: none"> • damaged valve stem seal • misfiring • too much oil in combustion chamber • worn cylinder and piston rings
white with formation of melt beads	Possibly indicates one or more of the following: <ul style="list-style-type: none"> • mixture too lean

BRP-Rotax MAINTENANCE MANUAL

Tips

- If both plugs have "white" electrodes with "melt" droplets, first suspect lean mixture. If calibration is correct and there is no evidence of manifold leaks, lack of fuel, or incorrect float settings, don't change the plugs to a colder range. Check if cooling system is operating correctly.
- Heavy oil deposits on the electrodes and insulator may cause engine problems, exchange regularly according to maintenance schedule, or at any indications of trouble.
- If after cleaning or changing the spark plugs, you still have an ignition problem, check if only one cylinder is affected or both. Some thought to what is common to both systems or only one will isolate the problem more efficiently. If no external fault is found, the ignition unit must be checked.

BRP-Rotax MAINTENANCE MANUAL

REPLACEMENT OF SPARK PLUGS

General note NOTE

To avoid spark plug damage, make sure to use a correct wrench/socket. Old spark plugs (mod. 99) = A/F 21 / hex. 21 mm (0.83 in.), new spark plugs (mod. 17) = hex. 16 mm (0.62 in.).

ATTENTION

Use of incorrect spark plugs can result in ignition problems and pre-ignition and consequent engine damage.

ATTENTION

Always change both plugs. Never interchange plugs from one cylinder to the other.

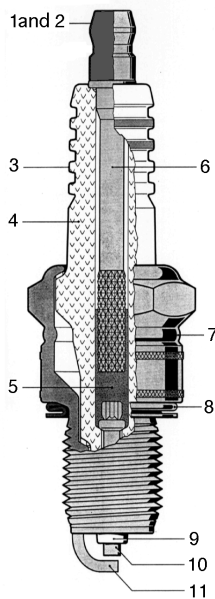

Figure 7.3

- | | |
|---|---|
| 1 Terminal nut inseparable on connection thread | 2 Connection thread |
| 3 Leakage current barrier | 4 Insulator (Al ₂ O ₃) |
| 5 Conductive enamel | 6 Terminal stud |
| 7 Upset- and heat-shrinkage zone | 8 Captive sealing ring |
| 9 Insulator nose | 10 Center electrode |
| 11 Ground electrode | |

BRP-Rotax
MAINTENANCE MANUAL

NOTE

The spark plug can be distinguished by the part no. and by the designation.

Spark plug mod. 99:

Step	Procedure
1	Apply a small amount of heat-conducting compound to spark plug threads.
2	Tighten the spark plugs to 27 Nm (20 ft. lb), only on cold engine.

Spark plug mod. 17:

Step	Procedure
1	Apply a small amount of heat-conducting compound to spark plug threads.
2	Tighten the spark plugs to 16 Nm (142 in. lb), only on cold engine.

BRP-Rotax
MAINTENANCE MANUAL

PROPELLER GEARBOX

CHECKING THE PROPELLER GEARBOX

B-type gearbox Place gearbox on a suitable support under hand press. See [Figure: Gearbox “B” type](#).

Step	Procedure
1	Place the mounting yoke, part no. 876880 on the dog gear (1)
2	Place angular ring (2) upside down (with “L” shape downwards) on prop shaft to facilitate reading of the distance A .
3	Apply a load of 16 kN (3600 lbs) on the dog gear via the mounting yoke. With this load, disk spring will be completely compressed.

ATTENTION
Do not exceed maximum load of 16 kN (3600 lbs), otherwise cover or dog gear will be damaged.

Step	Procedure
4	With spring in compressed state, measure A, the distance from top side of angular ring to lower edge of groove. See Figure: Gearbox “B” type .
5	Relieve pressure, remove all items from prop shaft and compensate distance A , by placing appropriate shims (3) under distance ring (4).
6	Shims are available as spare parts in the size 0.1 / 0.2 / 0.3 / 0.5 and 1.0 mm (0.0039 / 0.0079 / 0.0118 / 0.019 and 0.039 in.).

BRP-Rotax MAINTENANCE MANUAL

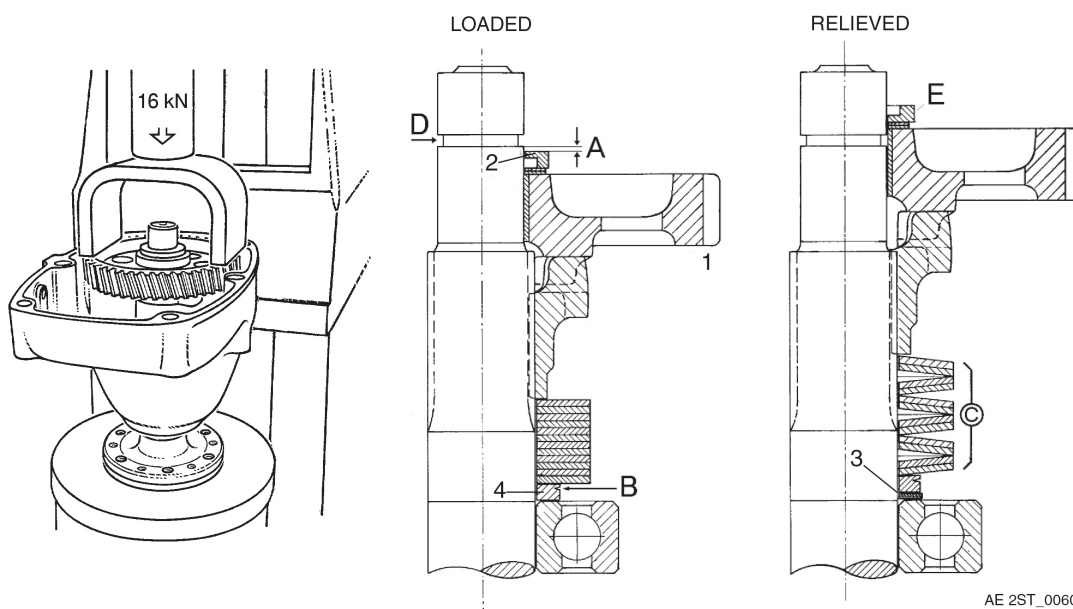

Figure 7.4: Gearbox "B" type

OIL CHANGE

ENVIRONMENTAL NOTE

Protect the environment.

Do not harm the environment by spilling oil. Dispose of oil in an environmentally friendly manner.

ATTENTION

Only use brand name oil in accordance with the latest Operators Manual.

Instruction

Renewing of the rotary valve lubrication oil.

NOTE

To change the oil the following steps are necessary:

Step	Procedure
1	Drain oil completely: For complete emptying, the engine must be inclined.
2	Afterwards refill the oil tank. Allow some time for setting.
3	Fill tank to max. mark and after a short trail run verify the oil level again.

Instruction

Check gearbox oil level, replace gearbox oil.

BRP-Rotax MAINTENANCE MANUAL

Step	Procedure
1	For draining the oil, remove drain plug. See Figure: Gearbox "B" type.
2	Replenish oil, until oil emerges at the respective lower oil level plug.

ATTENTION

The two large ventilation bores on both sides have to remain always open to warrant dissipation of heat at gearbox type "C" and "E".

Step	Procedure
3	Wire-secure vent screw, oil level plugs and drain plugs.

NOTE

Illustration shows "B" type gearbox.

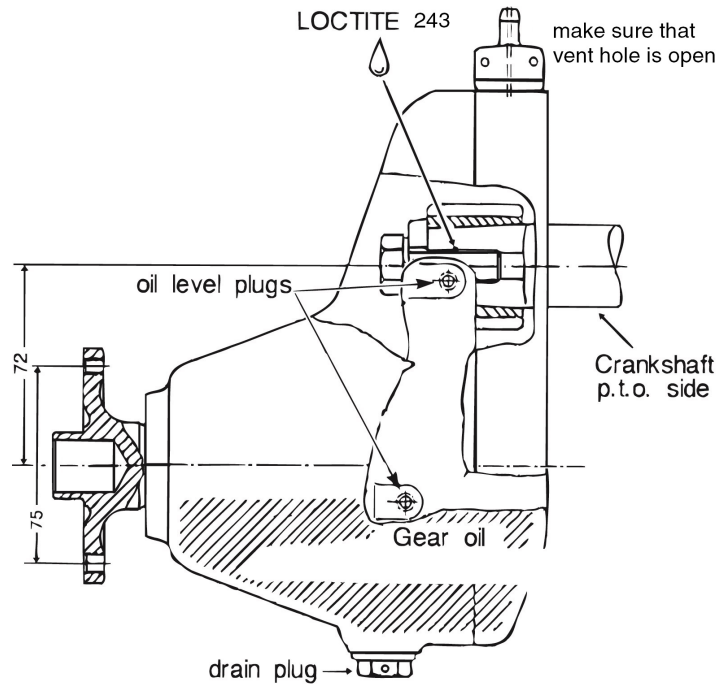

Figure 7.5: Gearbox "B" type

BRP-Rotax
MAINTENANCE MANUAL

CARBURETOR

CLEAN CARBURETOR AND CHECK FOR WEAR

- Stop engine at raised speed and verify float level
- Inspect carburetor assy. for leakage
- Check float valve for easy operation
- Inspect clip of jet needle for wear
- Inspect sieve sleeve
- Clean the carburetor with fuel as required

REPLACE JET NEEDLE AND NEEDLE JET

The needle jet and jet needle must only be exchanged by a mechanic with experience on two-stroke engines and in accordance with the relevant Maintenance Manual Heavy.

BRP-Rotax
MAINTENANCE MANUAL

FUEL PUMP

General note

Inspect the fuel pump in accordance with the manufacturers or the aircraft manufacturers instructions.

- Inspect the fuel pump
- Verify the fuel pressure: 0.2 – 0.5 bar (3 – 7 psi)

EXHAUST SYSTEM

RETORQUE OF EXHAUST MANIFOLD SCREWS

The screws of the exhaust manifold must be retightened to the specified torque:
22 Nm (195 in. lb)

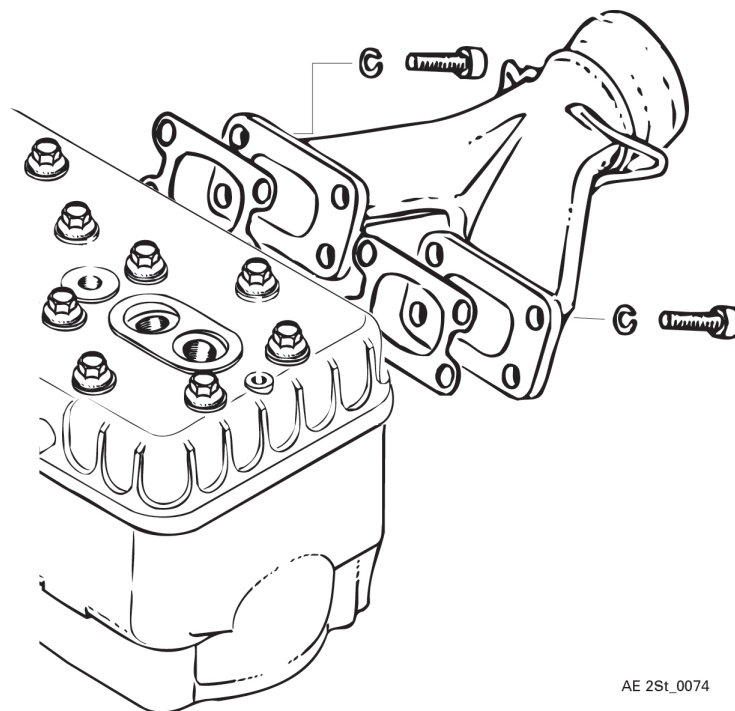

Figure 7.6

LUBRICATE BALL JOINTS

Check exhaust system prior to every flight for tightness, physical damage or changes in sound pattern. Especially inspect springs and hooks.

The muffler has to be supported on vibration damping blocks. All ball joints have to be greased regularly with heat resistant lubricant (e.g. Molykote G-N, 297 433) to avoid gripping or seizing of joints and consequent breaking of exhaust components.

REPLACE EXHAUST MUFFLER SPRINGS

Removing the
tension springs

See [Figure: Exhaust muffler spring.](#)

Step	Procedure
1	Remove the lock tabs from tension spring.
2	Inspect exhaust system for cracks and staining. Replace exhaust system with new if any external cracks are found. Do not weld cracks.

BRP-Rotax MAINTENANCE MANUAL

ATTENTION

Take care to use suitable protective equipment as disassembly .may result in cracking of the tension spring.

Step	Procedure
3	Detach tension springs with suitable tools one by one.
4	Clean ball joint with appropriate cleaning agent (dry rag or equivalent) and inspect for wear.

Inspecting of the tension springs

An affected (faulty) tension spring can be identified by black, bright surfaces.

Qualitatively flawless tension springs show dark brown, dull surfaces.

ATTENTION

After prolonged operation, due to high operating temperatures, there may be no distinct distinguishing features left as described that could aid in discerning the tension springs. Replace the tension springs in case of doubt.

Installation of the tension springs

Step	Procedure
1	Lubricate ball joint with heat-resistant lubricant (Molykote G-N or equivalent).
2	Install new tension springs with appropriate tools.
3	Exhaust springs shall be secured against loss and vibrations with wire.

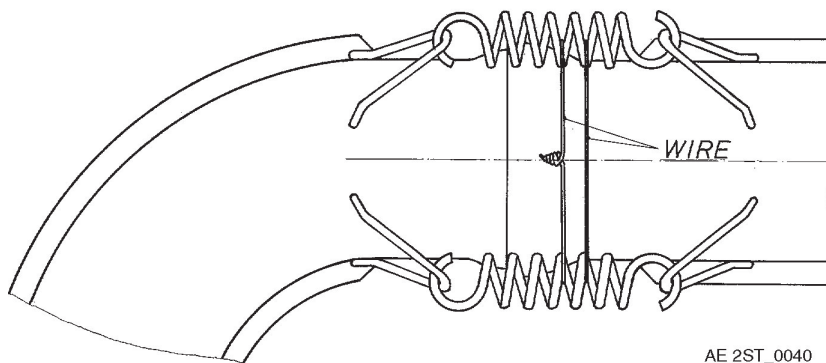

Figure 7.7: Exhaust muffler spring

BRP-Rotax
MAINTENANCE MANUAL

AIR FILTER

CLEANING THE AIR FILTER

General note

ATTENTION

Never use gasoline, steam, caustic liquids, strong detergents, particle cleaning agents or high pressure cleaners during this step.

ATTENTION

Do not dry over open flame, with compressed air or with hot air gun.

Cleaning

To clean the dry filter the following steps are necessary:

Step	Procedure
1	Lightly tap and brush off surface dirt and wet with cold water.
2	Roll filter in filter cleaning and degreasing fluid.
3	The level of the cleaning fluid should be approx. 3/4 of the height of corrugations. Dirty fluid must not run inside of filter. Allow at least 5 minutes to dissolve the dirt.
4	Rinse air filter with cold water from inside to outside. Shake off and let it dry in free air.

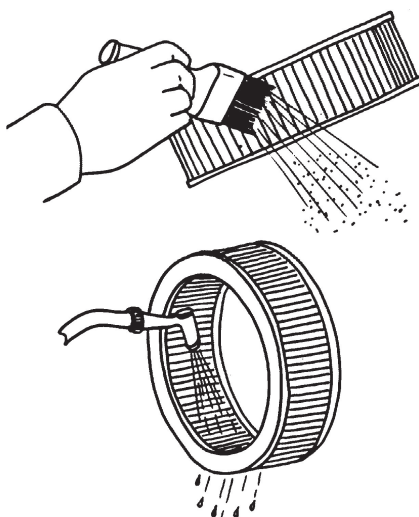

AE 2ST_0071

Figure 7.8: Cleaning the air filter

BRP-Rotax MAINTENANCE MANUAL

APPLICATION OF NEW AIR FILTERS

General note For a higher life-span and optimal engine protection the filter corrugations have to be moisturized with oil. Unoiled filters lose their effectiveness against dirt and dust. Every corrugation of the filter has to be oiled. After 5 - 10 minutes the filter mat will be soaked with oil, noticeable on the uniform red colouring

ATTENTION

Never use gear oil, diesel or engine oil, as they attract humidity.

NOTE

If necessary, apply filter oil on sealing face, but don't oil clamp connection area of filter.

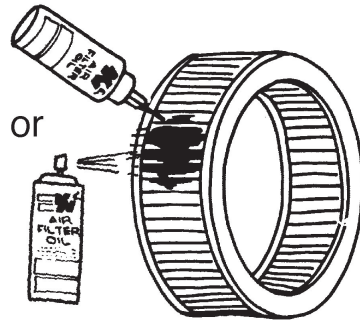

AE 2ST_0070

Figure 7.9: Overview

BRP-Rotax
MAINTENANCE MANUAL

FUEL FILTER

CHECK AND REPLACEMENT OF FUEL FILTER

General

The flow through the filter may be restricted due to the long term build up of dirt. A more serious type of blockage, which can occur quite rapidly is caused by a reaction between detergents in certain two-stroke oils and water in the fuel.

Both types of blockage may be difficult to detect visually. If blockage is suspected, renew fuel filter or filter element. Subsequently avoid water contamination of fuel.

BRP-Rotax
MAINTENANCE MANUAL

REWIND STARTER

Instruction **Check and replacement of the rewind starter.** See [Figure: Rewind starter.](#)

Step	Procedure
1	Remove the rewind starter assembly from the engine.
2	Remove the snap ring (1), loop spring (2), circlip (3) , pawl lock (4) and the pawl (5).
3	Check starter rope condition according to maintenance schedule. Replace if worn or frayed.

Instruction **To change the starter rope**

Step	Procedure
1	Pull out the starter rope fully to the end, hold starter housing (6) and rope sheave (7) together in their position. There is an opening in the rope sheave.
2	The key clamp (8) visible in the opening must be pushed out in the opposite sense of the pulling direction.
3	Pull the rope out of the rope sheave.

BRP-Rotax MAINTENANCE MANUAL

⚠ WARNING

Do not remove spring container (9), this might cause injuries. Do not operate the engine if the rewind starter is defective.

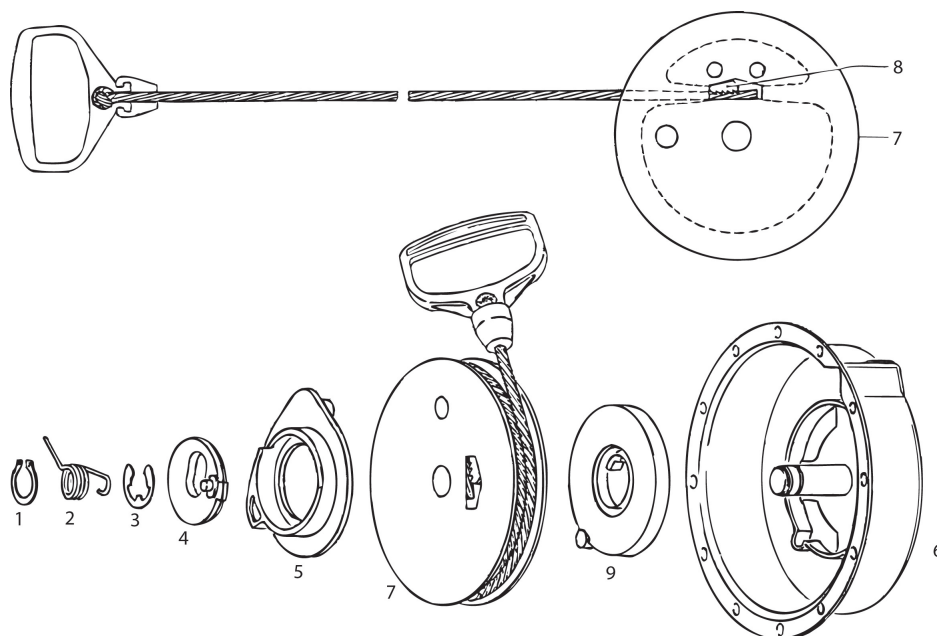

Figure 7.10: Rewind starter

- | | |
|--------------------|-------------------|
| 1 Snap ring | 2 Loop spring |
| 3 Circlip | 4 Pawl lock |
| 5 Pawl | 6 Starter housing |
| 7 Rope sheave | 8 Key clamp |
| 9 Spring container | |

Instruction

Installation of the rewind starter

Step	Procedure
1	Insert the new starter rope sheave, fit the key clamp in the same position as it was before.
2	Refit the parts pawl (5), pawl lock (4), circlip (3), loop spring (2) and snap ring (1).

BRP-Rotax
MAINTENANCE MANUAL

CHECK OF IGNITION SYSTEM

General

Verify all electrical connections for good contact and ensure they are free of corrosion. Inspect the wiring for wear, damage and corrosion.

Before flight the function of the two ignition circuits must be checked. For checking the ignition unit the engine must be operated at 3000 to 3500 rpm and alternately ignition circuit 1 and 2 must be switched off.

The rpm-drop must not exceed at 300 rpm.

BRP-Rotax MAINTENANCE MANUAL

Index

A

Abbreviations.....	4
Acceptable methods, techniques and practice	11
Air filter.....	15
Application of new air filters.....	16
Authorized personnel	3

C

Carburetor.....	11
Check and replacement of fuel filter.....	17
Check List/Maintenance Schedule.....	6
Check of ignition system.....	20
Check spark plug connectors.....	2
Checking the propeller gearbox.....	8
Cleaning, Air filter.....	15
Consumable Materials.....	7
Conversion table.....	7

D

Definition of terms	2
---------------------------	---

E

Engine check after propeller strike incidents.....	2
Engine submerging in water.....	4
Examination after engine failure	3
Exhaust system	13
Extreme climatic conditions.....	5

F

Fluid capacities.....	2
Fuel filter	17
Fuel pump	12

G

General.....	2
General overhaul, TBO.....	2

I

Influence by fire.....	5
------------------------	---

Inspection of spark plugs	2
Instruction	10

L

Life cycle	2
List of effective pages	1
Lubricate ball joints.....	13

M

Maintenance Concept.....	11
Maintenance Schedule	8
Maintenance schedule procedures	5

O

Oil change	9
Operating hours	2

P

Procedure notes	4
Propeller gearbox.....	8

R

Replace of exhaust muffler springs.....	13
Replacement of spark plugs.....	6
Replacing the rewind starter.....	18
Replenishing operating fluids	1
Reporting	6

S

Safety	8
Safety information	9
Scheduled maintenance	1
Scheduled maintenance checks	1-2
Spark plugs	2

T

Table of amendments	1
Technical documentation	12

BRP-Rotax
MAINTENANCE MANUAL

Terms 4
Time limit 2
Time Limit 4
Time limit for the coolant 5
Time limit, parts 5
Time limits 1
Trouble shooting 6
Type description 3

U

Unscheduled maintenance checks 3, 1
Use for intended purpose 14

V

Visual inspection 4

WARNING

Before starting any maintenance work, please read the Maintenance Manual completely as it contains important safety relevant information. Failure to do so may result in personal injuries including death. Consult the original equipment manufacturers handbook for additional instructions!

These technical data and the information embodied therein are the property of BRP-Rotax GmbH & CO KG, Austria, acc, BGBl 1984 no. 448, and shall not, without prior written permission of BRP-Rotax GmbH & Co KG, be disclosed in whole or in part to third parties. This legend shall be included on any reproduction of these data, in whole or in part. The Manual must remain with the engine/aircraft in case of sale.

ROTAX® is a trade mark of BRP-Rotax GmbH & Co KG. In the following document the short form of BRP-Rotax GmbH & Co KG = BRP-Rotax is used.

Other product names in this documentation are used purely for ease of identification and may be trademarks of the respective company or owner.

Copyright 2018 © - all rights reserved.

Translation into other languages might be performed in the course of language localization but does not lie within ROTAX® scope of responsibility.

In any case the original text in English language and the metric units are authoritative.



Engine serial no.

Type of aircraft

Aircraft registration no.

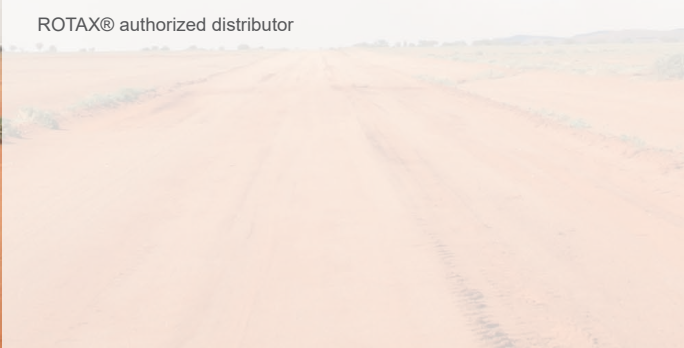

ROTAX[®] authorized distributor